

Location Hydraulics Report

Prepared for Bay County Board of County Commissioners

Philip Griffitts Senior Parkway, Phase III

From Clara Avenue to Chip Seal Parkway

Bay County, Florida

FPID No.: 442483-4-34-01 & 442483-4-34-02

ETDM Number: 14562



Prepared By:

Kimley-Horn

120 Richard Jackson Blvd #230
Panama City Beach, FL 32407

May 2026

PROFESSIONAL ENGINEER CERTIFICATION

I hereby certify that I am a registered professional engineer in the State of Florida practicing with **Kimley-Horn and Associates, Inc.** and that I have supervised the preparation and approve the findings, opinions, conclusions, and technical advice hereby reported in:

REPORT: Location Hydraulics Report

PROJECT: Philip Griffitts Senior Parkway Phase III from Clara Avenue to Chip Seal Parkway

The following duly authorized engineering business performed the engineering work represented by this document:

Kimley-Horn & Associates, Inc.

120 Richard Jackson Blvd #230

Panama City Beach, FL 32407

Telephone: (850) 553-3522

FL Certificate of Authorization No. 696

This report contains calculations for hydrologic and hydraulic analysis for the above roadway improvement project. The information used to determine hydrologic and hydraulic parameters for the calculations was based on the best available information at the time of the analysis.

I acknowledge that the procedures and references used for this report and its calculations are standard to the practice of civil engineering as applied through professional judgement and experience.

THE OFFICIAL RECORD OF THIS REPORT IS THE ELECTRONIC FILE DIGITALLY SIGNED AND SEALED UNDER RULE 61G15-23.004, F.A.C.

THIS DOCUMENT HAS BEEN
DIGITALLY SIGNED AND SEALED BY:

PREPARED BY: James C. Donahue

PE NUMBER: 98320

DATE:

PRINTED COPIES OF THIS DOCUMENT ARE
NOT CONSIDERED SIGNED AND SEALED.
THE SIGNATURE MUST BE VERIFIED ON
THE ELECTRONIC DOCUMENT.

Table of Contents

1.0	Introduction	4
1.1	Project Description	4
1.2	Purpose and Need.....	7
1.2.1	Purpose	7
1.2.2	Need and Safety	7
1.3	Alignment	7
1.3.1	Preferred Alternative	7
2.0	Existing Conditions.....	12
2.1	Drainage Basins	12
2.2	Land Use.....	14
2.3	Soils	14
3.0	Floodplain Involvement and Classification.....	15
3.1	Floodplains	15
3.2	Floodways	15
3.3	Wetlands	16
4.0	Risk Assessment.....	16
5.0	Recommendations and Conclusion.....	16
	APPENDICES.....	17
	Appendix A.....	18
	Appendix B.....	24
	Appendix C.....	26
	Appendix D.....	28

List of Figures

Figure 1:	Project Location Map	6
Figure 2:	PGS Ph. III Typical Section	9
Figure 3:	Clara Avenue Extension Typical Section.....	10
Figure 4:	Alf Coleman Road Extension Typical Section.....	10
Figure 5:	Longpoint Way Extension Typical Section.....	11

List of Tables

Table 1:	Anticipated Cross Drains.....	13-14
----------	-------------------------------	-------

1.0 Introduction

This Location Hydraulic Report (LHR) is required by 23 CFR Part 650A and is one in a progression of technical deliverables required as part of the PD&E Study. The LHR examines the engineering and environmental impacts to the floodplain as outlined in the FDOT PD&E Manual, FDOT Design Manual (FDM), and the project objectives.

The purpose of the LHR is to assess potential base floodplain encroachments and required compensation resulting from the new roadway alignment as well as impacts related to cross drain hydraulics consequential to the roadway project. In accordance with Executive Order 11988 “Floodplain Management”, USDOT Order 5650.2, “Floodplain Management and Protection”, and Federal-Aid Policy Guide 23 CFR 650A, the floodplain must be protected. These regulations intend to avoid or minimize encroachments within the 100-year floodplain, where practicable, and to avoid supporting land use development detrimental to the floodplain watershed.

This report identifies and assesses potential impacts to floodplain storage and evaluates the corresponding transportation improvements to the existing water works. The entirety of the project is located within a Federal Emergency Management Agency (FEMA) designated hurricane surge zone. Because of this, project impacts to the existing FEMA floodplain are not expected to require volumetric compensation. Instead, cross drains throughout the project will be sized appropriately using Interconnected Pond Routing 4 (ICPR4) to convey the 100-year design storm event without causing adverse impacts to properties upstream (south) of the proposed corridor. Wetland impacts will require mitigation through the Northwest Florida Water Management District (NFWFMD). A summary of the environmental and wetland impacts of the project can be found in the project's Natural Resource Evaluation (NRE) report.

1.1 Project Description

Philip Griffitts Senior (PGS) Parkway is a proposed new road approximately one mile north of US 98 (SR 30A/Panama City Beach Parkway) between SR 79 (N. Arnold Road) and Chip Seal Parkway. This project, Phase III of the PGS Parkway, extends from Clara Avenue to Chip Seal Parkway in Bay County, Florida (**Figure 1**: Project Location Map). The total distance of Phase III is approximately 5.1 miles.

This primarily east-west facility will provide a two-lane (major collector) roadway with 11-foot travel lanes, five-foot paved shoulders, curb and gutter, and a 12-foot shared-use path for most of the project length (**Figure 2**: Typical Section). The estimated right-of-way (ROW) width for the proposed project, including side slopes tying down to the

existing grade, is 200 feet. The ROW is proposed to include extra width to accommodate several new utility lines for the City of Panama City Beach, to provide critical redundancy to the City's water and wastewater utility network.



Figure 1: Project Location Map

1.2 Purpose and Need

1.2.1 Purpose

The purpose of the PGS Parkway Phase III project is to improve mobility in the study area by providing an alternative to US 98 (SR 30A/Panama City Beach Parkway) for local traffic; to enhance vehicular and pedestrian connectivity to J.R. Arnold High School, A. Gary Walsingham Academy, the Panama City Beach Publix Sports Park, and the Breakfast Point neighborhood; and to address safety concerns on US 98 (SR 30A/Panama City Beach Parkway) within the study limits by reducing congestion.

A secondary purpose is to enable risk reduction and resiliency of the transportation network by providing an alternate route that is constructed above the storm surge elevation in the coastal high hazard area.

1.2.2 Need and Safety

Study area needs to be addressed include: provision of an additional link within the transportation network to provide an alternative to currently congested routes; accommodation of existing traffic and future transportation demand on the study area road network; improvement in safety on existing roads; and provision of a reliable alternate route for emergency responders. This project is a new alignment.

1.3 Alignment

Three Build Alternatives were considered for PGS Parkway, Phase III in addition to the No-Build Alternative. The three alternatives differed primarily in horizontal alignment.

Alignment M1 was the furthest north (and therefore the furthest from the Breakfast Point development), Alignment M3 was the furthest south (and therefore the nearest to the Breakfast Point development), and Alignment M2 was between Alignment M1 and Alignment M3. All three horizontal alignment alternatives converged near the eastern extents of the existing Breakfast Point development before connecting with the roundabout at the eastern terminus intersection with Chip Seal Parkway.

The No-Build Alternative assumes PGS Parkway, Phase III is not constructed. The No-Build Alternative was considered a viable alternative throughout the PD&E Study.

1.3.1 Preferred Alternative

The preferred alternative is Build Alternative M1, which proposes the following elements:

- An approximate 2,000-foot extension of Clara Avenue with a two-lane typical section (one travel lane in each direction).
- A one-lane roundabout to facilitate northbound-to-eastbound and westbound-to-southbound traffic between Clara Avenue and PGS Parkway, Phase III.
- Construction of PGS Parkway, Phase III from Clara Avenue to Chip Seal Parkway with a two-lane typical section (one lane in each direction) and a 10–12 foot shared use path.
- An approximate 800-foot extension of Alf Coleman Road with northbound stop-control at the intersection with the new PGS Parkway, Phase III roadway.
- An approximate 650-foot extension of Longpoint Way with northbound stop-control at the intersection with the new PGS Parkway, Phase III roadway.

Build Alternative M1 meets the purpose of the project by providing parallel relief to US 98 (SR 30A/Panama City Beach Parkway) between Clara Avenue and Chip Seal for local traffic; by enhancing vehicular and multimodal connectivity to J.R. Arnold High School, A. Gary Walsingham Academy, the Panama City Beach Publix Sports Park, and the Breakfast Point neighborhood; and by improving safety along US 98 (SR 30A/Panama City Beach Parkway) by reducing congestion.

Build Alternative M1 meets the needs of the project by providing an alternative link within the local transportation network to currently congested routes (primarily US 98 [SR 30A/Panama City Beach Parkway]), accommodating future transportation demand on the surrounding network, improving safety on existing roads by reducing congestion, and providing a reliable alternate route for emergency vehicles to and from the schools and neighborhoods north of US 98 (SR 30A/Panama City Beach Parkway) between Clara Avenue and Chip Seal Parkway).

PGS Parkway Phase III Typical Section

The proposed typical section for PGS Parkway is the same for the three proposed alternatives. The proposed typical section from Clara Avenue to the St. Joe Property Line and from Alf Coleman Road to Chip Seal Parkway is shown in **Figure 2**. The typical section consists of 11-foot wide travel lanes (one in each direction), a 5-foot paved shoulder in both directions, a 12-foot shared use path on the south side of the road, and a grassed utility strip on the north side of the road. The proposed ROW width is 200-feet.

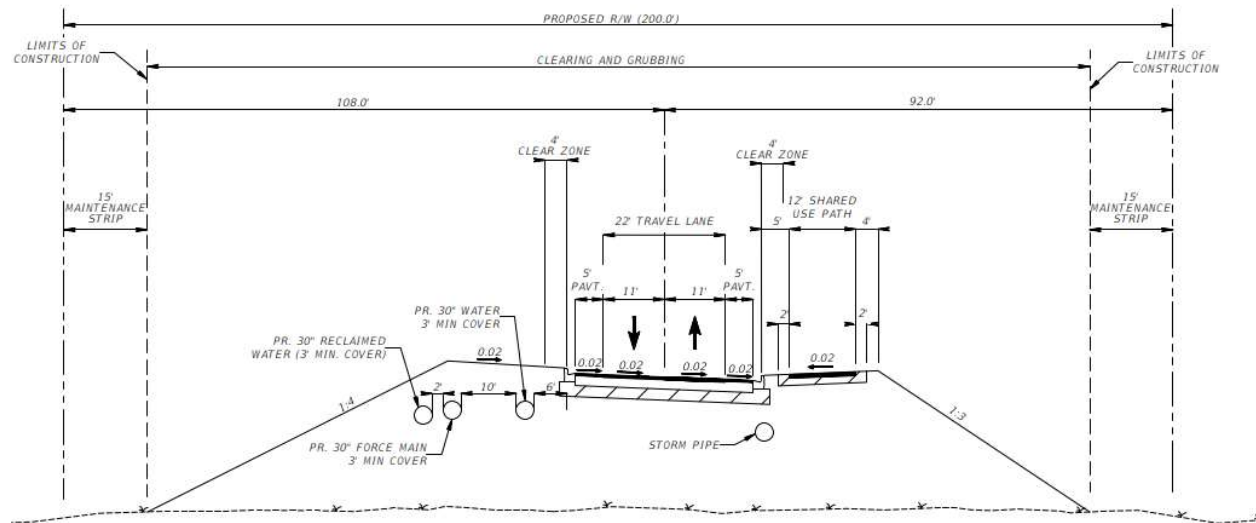

Figure 2: PGS Ph. III Typical Section

Clara Avenue Extension Typical Section

The proposed typical section for the extension of Clara Avenue includes 11-foot wide travel lanes (one in each direction) and a 5-foot paved shoulder in both directions of travel. A 6-foot wide sidewalk would be extended on the western side of Clara Avenue, consistent with the existing typical section. The 100-foot right-of-way typical section for the Clara Avenue extension is shown in **Figure 3**.

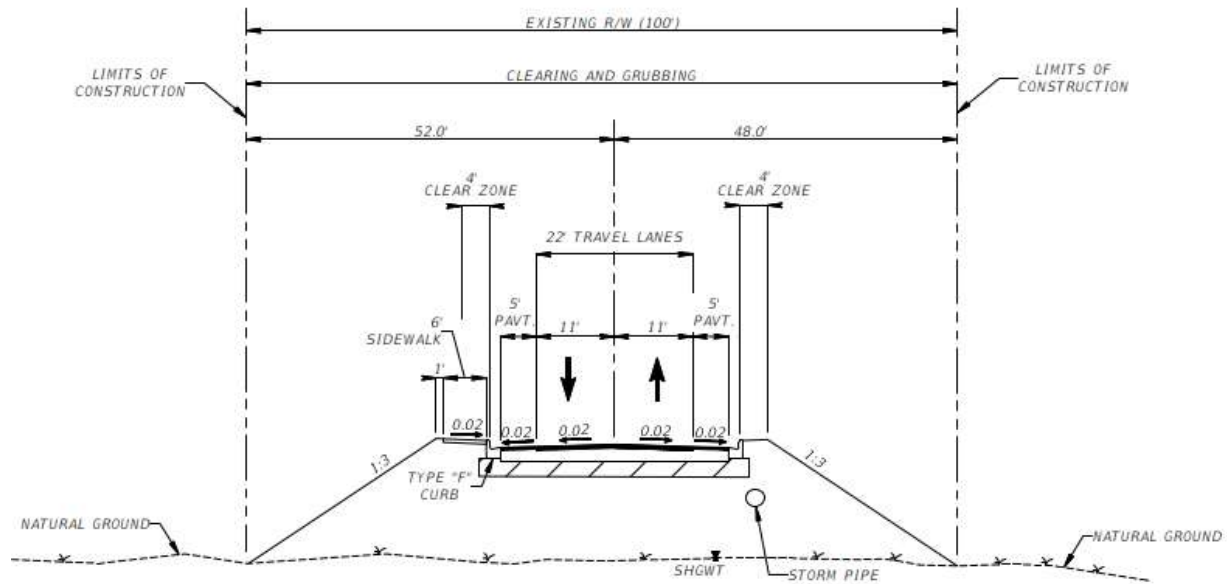

Figure 3: Clara Avenue Extension Typical Section

Alf Coleman Road Extension Typical Section

The proposed typical section for the extension of Alf Coleman Road includes four 12-foot wide travel lanes (two in each direction), a 15.5-foot raised grass median, a 5-foot paved shoulder in both directions of travel, a 12-foot shared use path on the west side of the roadway, and a 6-foot sidewalk on the east side of the roadway. The 190-foot right-of-way typical section for the Alf Coleman Road extension is shown in **Figure 4**.

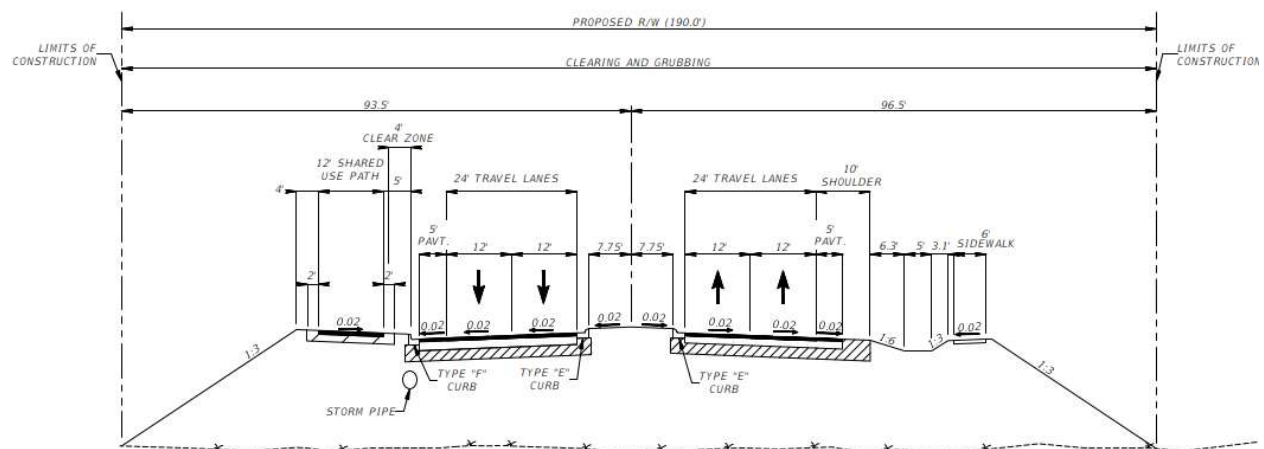

Figure 4: Alf Coleman Road Extension Typical Section

Longpoint Way Extension Typical Section

The proposed typical section for the extension of Longpoint Way includes two 11-foot wide travel lanes (one in each direction) and 6-foot sidewalks on both the east and west side of the roadway. The 115-foot right-of-way typical section for the Longpoint Way extension is shown in **Figure 5**.

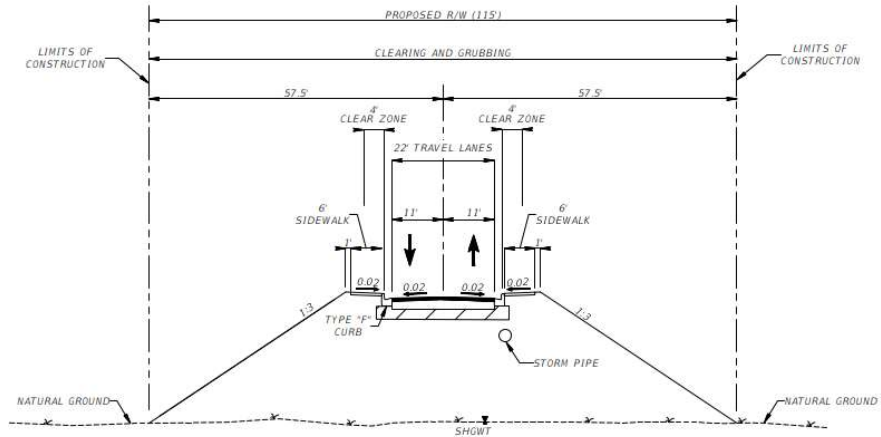

Figure 5: Longpoint Way Extension Typical Section

2.0 Existing Conditions

The construction of PGS Parkway is planned to be completed in phases. The current phase, Phase III, is planned to connect Clara Avenue to Chip Seal Parkway. Phases I and II of PGS Parkway have already been constructed. Phase I was completed in 2017 and extends 1.4 miles from SR 79 to Pier Park Drive. Phase II was completed in 2021 and created a 2.4-mile segment that connected Pier Park Drive to Nautilus Street. Future study will assess options for connecting Nautilus Street to Clara Avenue. No previous study has directly evaluated the Phase III connection between Clara Avenue and Chip Seal Parkway. There are no existing cross drains, bridges, or permits. The extents of the project fall within the following Water Body Identification (WBID) codes created and maintained by the Florida Department of Environmental Protection (FDEP): Intercoastal Waterway (ICWW) (WBID: 1008), the Bothereation Bayou (WBID 1099), Basin Bayou (WBID: 1092), Harrison Bayou (WBID: 1105), Unnamed Bayou (1119). The ultimate outfall is West Bay (WBID 1061A) to the north. The current Panama City Beach regional stormwater model and the approved FEMA XPSWMM stormwater model for the regional area were combined into ICPR4 and updated to delineate basins along the proposed corridor and estimate pre/post development flow rates and stages.

2.1 Drainage Basins

Forty (40) basins adjacent to the proposed project were identified in the existing conditions within the limits of the study area (**Appendix A**). Detailed information about each drainage basin is available in the Pond Siting Report (PSR) for the project. Basins and sub-basins have been defined to correlate with anticipated cross drains locations. 2020 Light Detection and Ranging (LiDAR) elevations used in the delineation of basins were sourced from the National Oceanic and Atmospheric Administration (NOAA). In addition to this data, field visits, and permitted information sourced from NFWFMD for adjacent developments were used where applicable. All basins within the corridor are considered open basins.

The existing basins that the project will bisect consist of forested wetlands and swampy regions. The basins also feature a network of intermittent and varying sizes of canals and swales, directing water flow typically from south to north, into the West Bay.

Flows for anticipated cross drains were calculated from the ICPR4 model developed for the project. The 100yr-24hr SCS III storm event was used in the analysis and an assumed velocity of 4 feet per second (fps) was used to calculate appropriate cross drain sizes. See **Table 1** for values and specifications relating to each anticipated cross drain. Special scour protection design will be necessary for high flow cross drains and

will be analyzed in more detail during the design phase.

Table 1: Anticipated Cross Drains

Basin	CD No.	Station	Max Flow (cfs)	Count	Span (in)	Rise (in)	Type
B001	CD101	54+03	22.09	2	24	24	RCP
B002	CD102	54+56	1.52	1	18	18	RCP
B003	CD103	56+71	17.79	2	24	24	RCP
B004	CD104	107+59	110.7	4	36	36	RCP
B005	CD105	114+38	0	n/a	n/a	n/a	RCP
B006	CD106	119+45	23.83	2	24	24	RCP
B007	CD107	123+57	10.06	1	24	24	RCP
B008	CD108	127+06	213.81	1	240	36	CBC
B009	CD109	145+07	257.66	1	264	36	CBC
B010	CD110	156+38	40.23	4	24	24	RCP
B011	CD111	159+54	326.07	1	336	36	CBC
B011	CD112	168+89	71.2	4	30	30	RCP
B012	CD113	174+35	10.96	1	24	24	RCP
AC0102	CD114	181+05	511.02	1	516	36	Bridge Culvert
B013	CD115	188+37	157.68	1	168	36	CBC
B014	CD116	202+45	319.1	1	336	36	CBC
B015	CD117	209+19	343.55	1	348	36	CBC
B016	CD118	219+33	131.88	1	132	36	CBC
B017	CD119	230+48	176.15	1	180	36	CBC
B018	CD120	232+32	22.58	2	24	24	RCP
B019	CD121	245+14	722.88	1	720	36	Bridge Culvert
B020	CD122	247+77	337.31	1	348	36	CBC
B021	CD123	261+62	93.87	4	36	36	RCP
B022	CD124	266+80	103.09	4	36	36	RCP
B023	CD125	274+38	63.01	4	30	30	RCP
B024	CD126	283+20	46.18	4	24	24	RCP
B025	CD127	283+45	14.06	2	18	18	RCP
B026	CD128	288+42	76.11	4	30	30	RCP
B027	CD129	301+08	31.16	3	24	24	RCP
B028	CD130	310+76	40.15	4	24	24	RCP
B029	CD131	312+72	70.18	4	30	30	RCP
B030	CD132	316+30	14.35	2	24	24	RCP

B031	CD133	316+71	10.47	1	24	24	RCP
B032	CD134	320+38	3.27	1	18	18	RCP

2.2 Land Use

Land use in the drainage basins associated with the cross drains and floodplains vary throughout the corridor and includes commercial, residential, and preservation area. The land use dataset was compiled by Bay County in 2025 (**Appendix B**).

2.3 Soils

Soils in the area are a mixture of different types of sand with hydrologic soil group classifications of (A/D). The dual classification is representative of soils with high hydraulic conductivity rates that reside in areas with a high groundwater table (<2-ft). Soils in the area most likely infiltrate at a high rate during the dry season and poorly during the wet season.

Based on the soil classifications found in the United States Department of Agriculture (USDA) and the National Resources Conservation (NRCS) Soil Survey for the project corridor, the project study area is comprised of 15 soil types as listed below and illustrated in **Appendix C**.

- 13: Leon Sand, 0 to 2 percent slopes
- 22: Pamlico-Dorovan Complex
- 23: Chipley Sand, 0 to 5 percent slopes
- 27: Mandarin Sand, 0 to 2 percent slopes
- 29: Rutlege Sand, 0 to 2 percent slopes
- 30: Pottsburg-Pottsburg, wet, sand, 0 to 2 percent slopes
- 40: Arents, 0 to 5 percent slopes
- 41: Dirego Muck
- 42: Resota Fine Sand, 0 to 5 percent slopes
- 43: Urban Land
- 44: Beaches
- 45: Kureb Sand, 0 to 5 percent slopes
- 47: Pits
- 52: Bayvi Loamy Sand
- 99: Water

3.0 Floodplain Involvement and Classification

The FEMA identifies flood hazards, assesses flood risks, and provides data to guide stakeholders in taking effective mitigation actions which would increase public safety. A review of the FEMA Flood Insurance Rate Maps (FIRM) indicates the project area is within Floodplain A, AE, and X.

3.1 Floodplains

A floodplain is defined in the FDOT Project Development and Environment Manual, July 31, 2024, as “any land area susceptible to being inundated by floodwaters from any source.” The following FEMA FIRM contain the project area: 12005C0302J, 12005C0304J, 12005C0308J, 12005C0309J. The majority of the project is located within FEMA regulated Flood Zone A (floodplain elevation not established) and Flood Zone AE with base flood elevations (BFE) ranging from 8’-10’ (NAVD88). A small portion of the project is located within Flood Zone X (0.2% annual chance flood hazard). The FEMA Flood Maps and FIRM are shown in **Appendix D**.

As can be seen in **Appendix D**, the entirety of the project limits is within a FEMA flood zone. This is the case for all alternative roadway routes evaluated, so encroachment is unavoidable. Floodplain impact volumes were calculated with a CAD-generated cut/fill grading report from the project’s 30% concept plans for the preferred alternative. This report estimated fill impacts between existing ground and elevation 9.0’ (a conservative representative estimate of the 100-year FEMA storm surge elevation for the entire project) for the entire project excluding the pond sites. The resulting impact volume was approximated to be 326,000 CY. The encroachments are considered significant, however; the 100-year FEMA floodplain is a direct result of storm surge, so the encroachments are not expected to require volumetric compensation or minimization efforts. Instead, cross drains throughout the project will be sized appropriately to convey the 100-year design storm event to create minimal or no rise to the base flood elevation and to ensure wetland connectivity is maintained. This approach was discussed and verbally approved by the Bay County flood-management/stormwater department during a meeting on March 25th, 2025. Due to this methodology, no adverse impacts are anticipated to occur to private property upstream or downstream. In total, thirty-four (34) new cross drain culverts are anticipated along the corridor.

3.2 Floodways

There are no known regulated floodways within the project area. Because the site sits directly adjacent to tidally influenced waters (West Bay), the flood elevations listed in the

FEMA FIRM maps are based upon estimated hurricane surge elevations. **Appendix D** depicts FEMA Flood Hazard Zones and Estimated Tidal Surge Zones respectively.

3.3 Wetlands

Ecological communities within the project corridor include freshwater wetlands (roughly 60% of the area within project limits), upland forest and upland prairie habitats. A large portion of the corridor occurs within the limits of the Breakfast Point Mitigation Bank, a state and federal permitted site that generates wetland credits to offset impacts elsewhere within the regional watershed. Anticipated impacts to the mitigation bank as well as to existing conservation easements are addressed in the Natural Resources Evaluation (NRE) report for this project. Adverse impacts to natural and beneficial floodplain values outside the project limits are not anticipated since existing flow-ways are being maintained.

4.0 Risk Assessment

There is no significant change in flood risk associated with the proposed improvements within the project area. The purpose is to enable risk reduction and resiliency of the transportation network by providing an alternate route that is constructed above the storm surge elevation in the coastal high hazard area.

5.0 Recommendations and Conclusion

This project will promote risk reduction and resiliency of the transportation network by providing an alternate route that is constructed above the storm surge elevation in a coastal high-hazard area. A new ICPR4 model was created by merging the existing Panama City Beach regional model and the existing FEMA XPSWMM model for the area. The resulting ICPR4 model was modified to increase detail adjacent to the proposed corridor. Based on the flows generated by the ICPR4 model, preliminary cross drain locations and sizes were determined. In total, thirty-four (34) new cross drains along the corridor are anticipated. Additional design to optimize the sizing and locations of the proposed cross drains will be needed during the design phase of the project and should be done in accordance with the FDOT Drainage Manual.

APPENDICIES

Appendix A

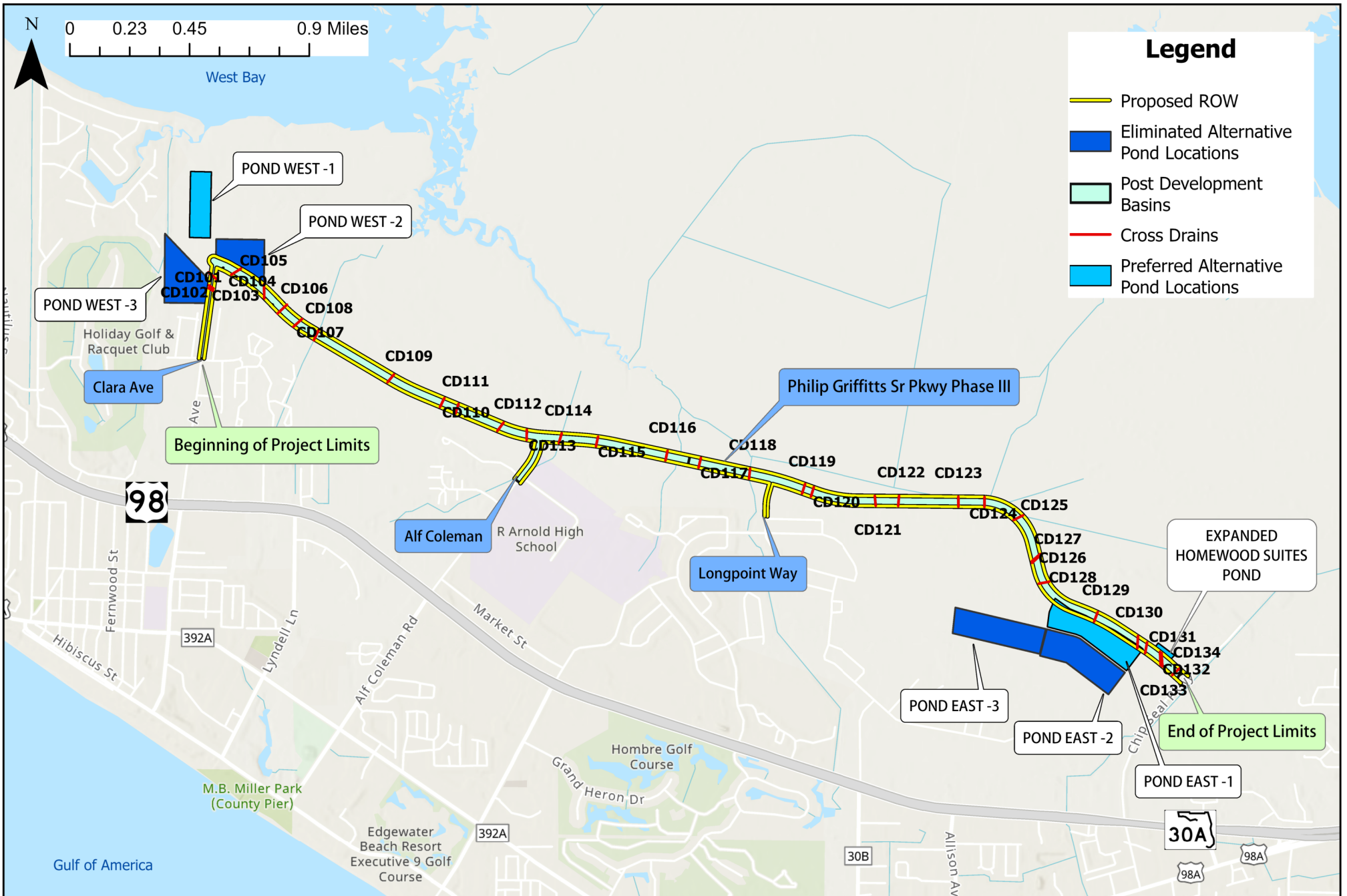

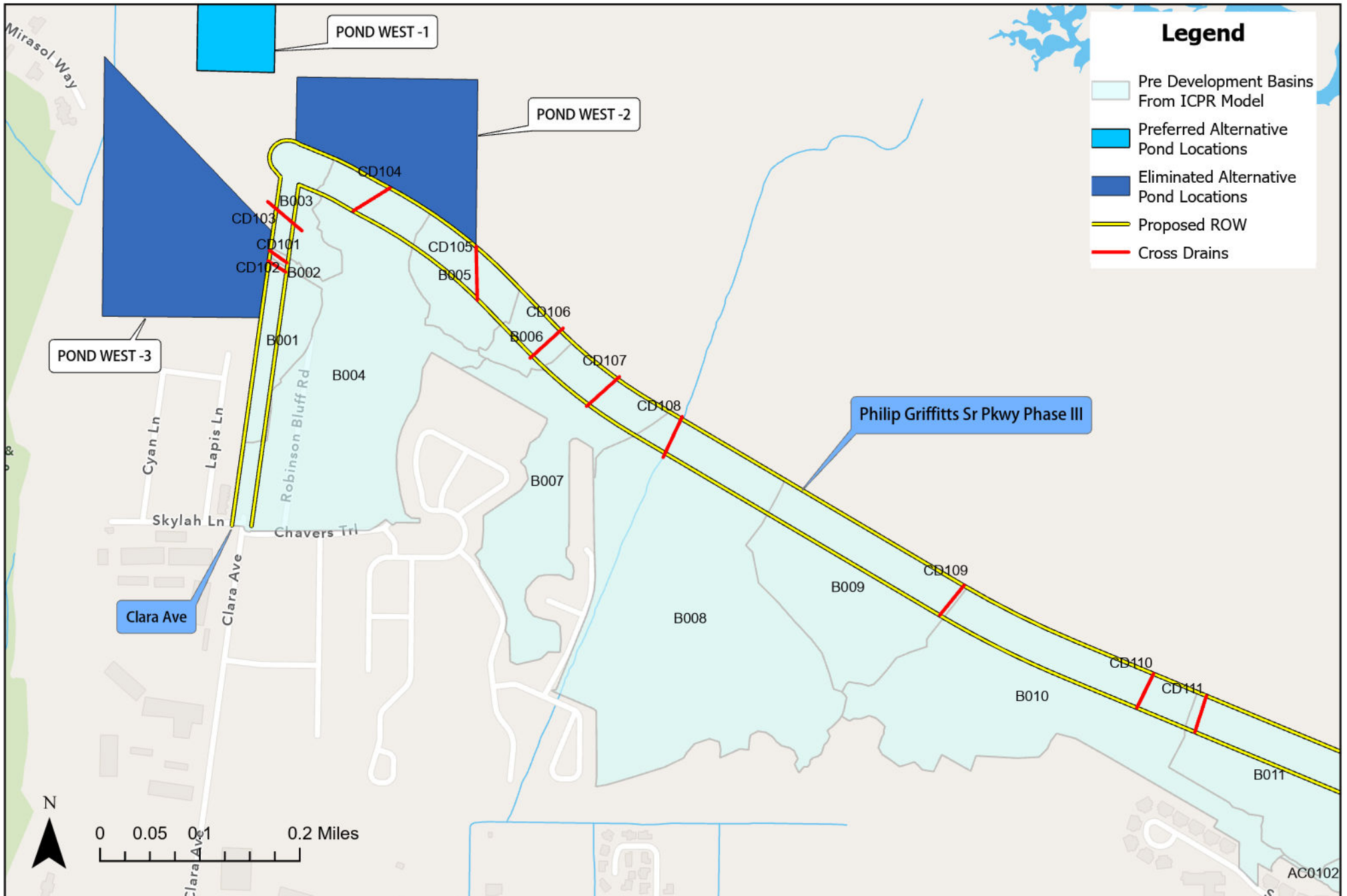

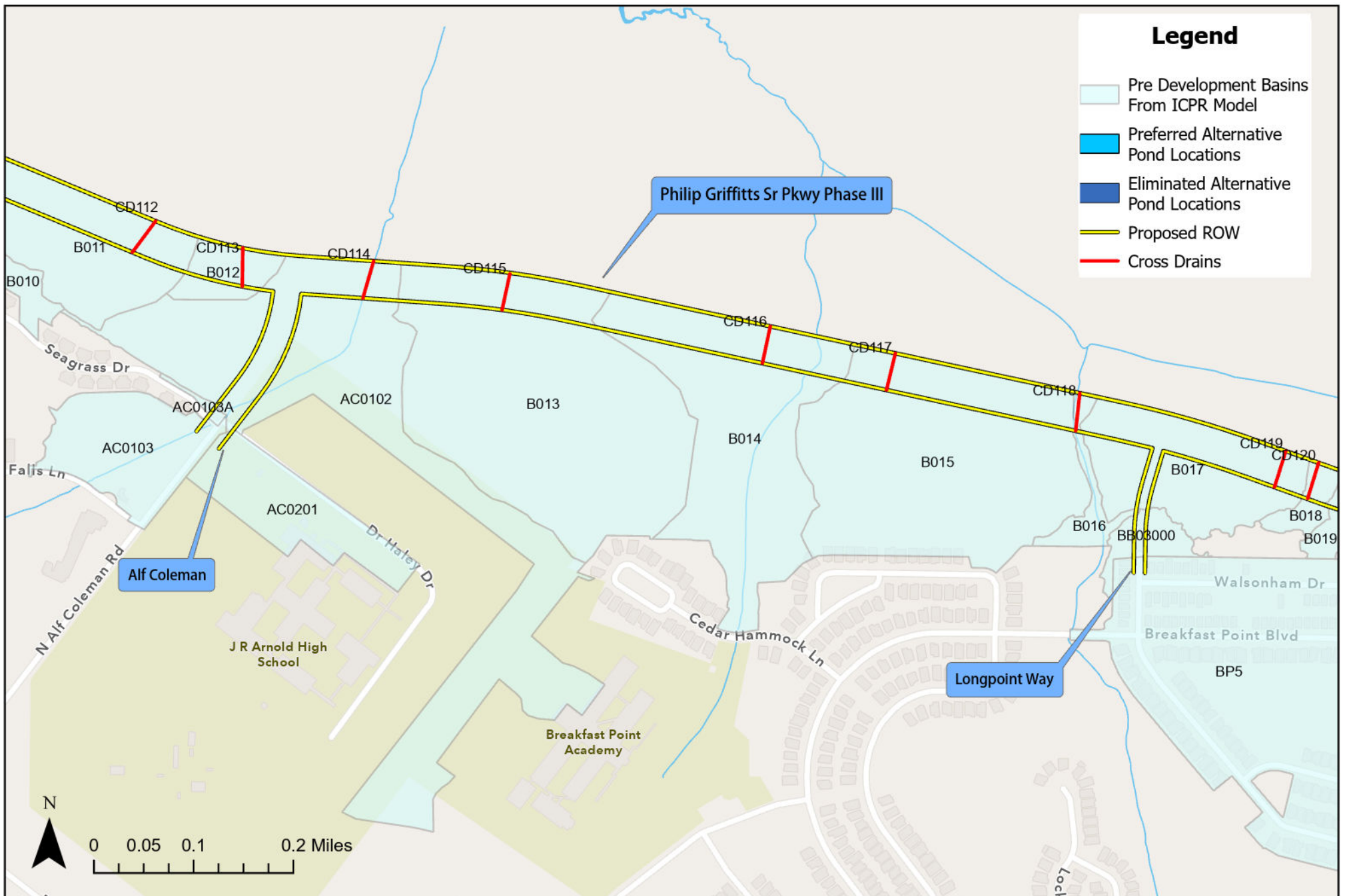

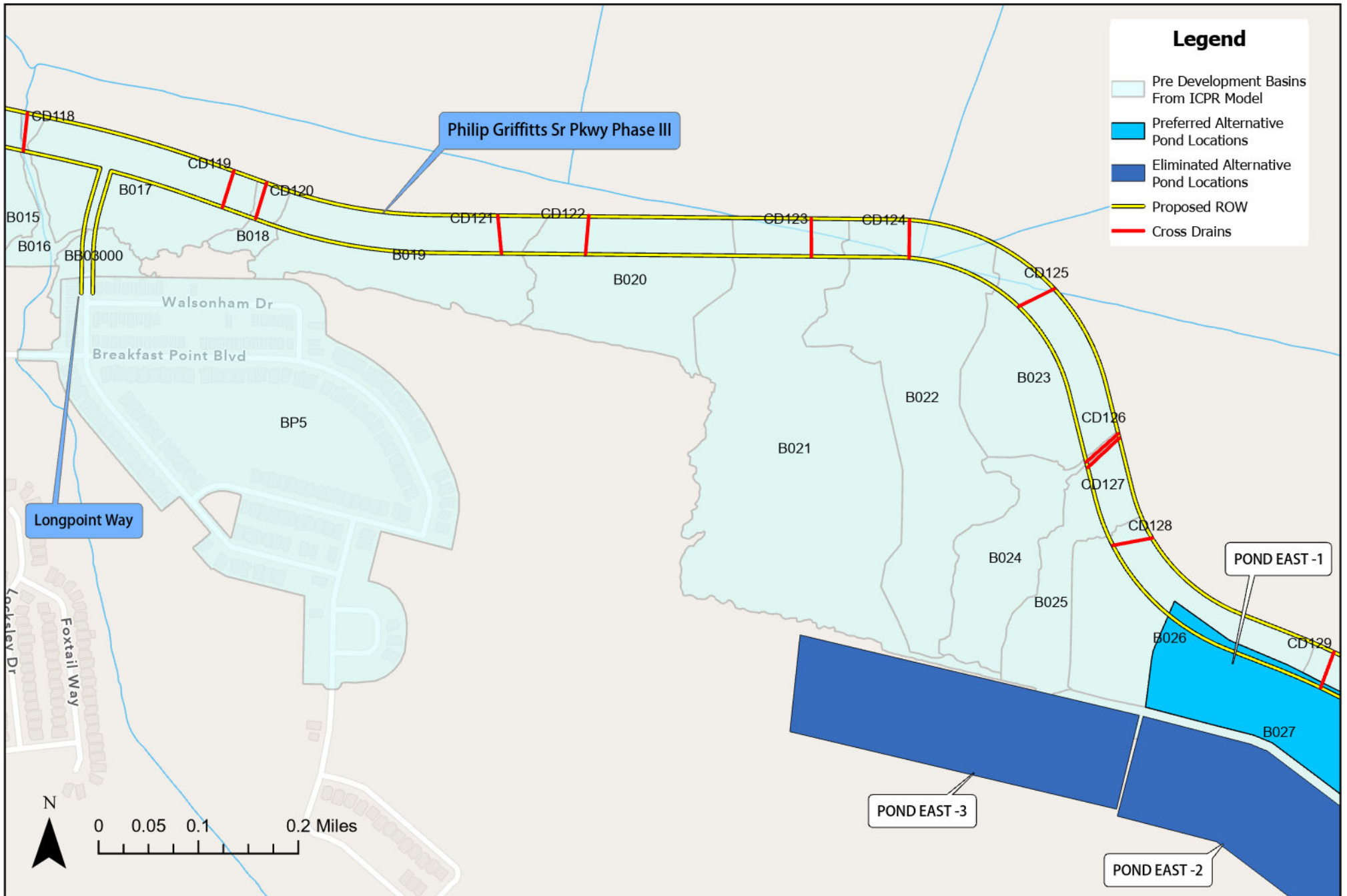

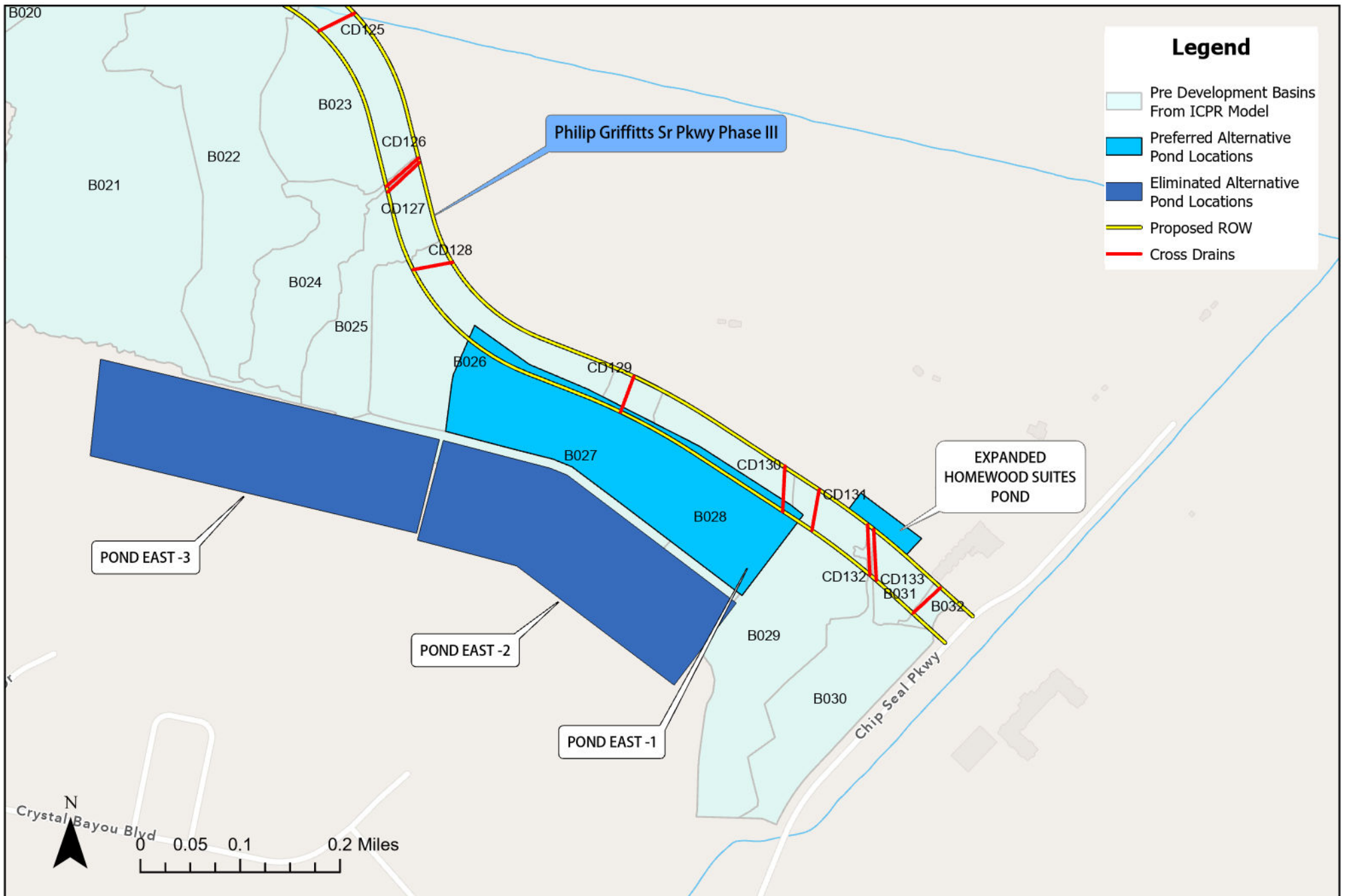

Appendix B

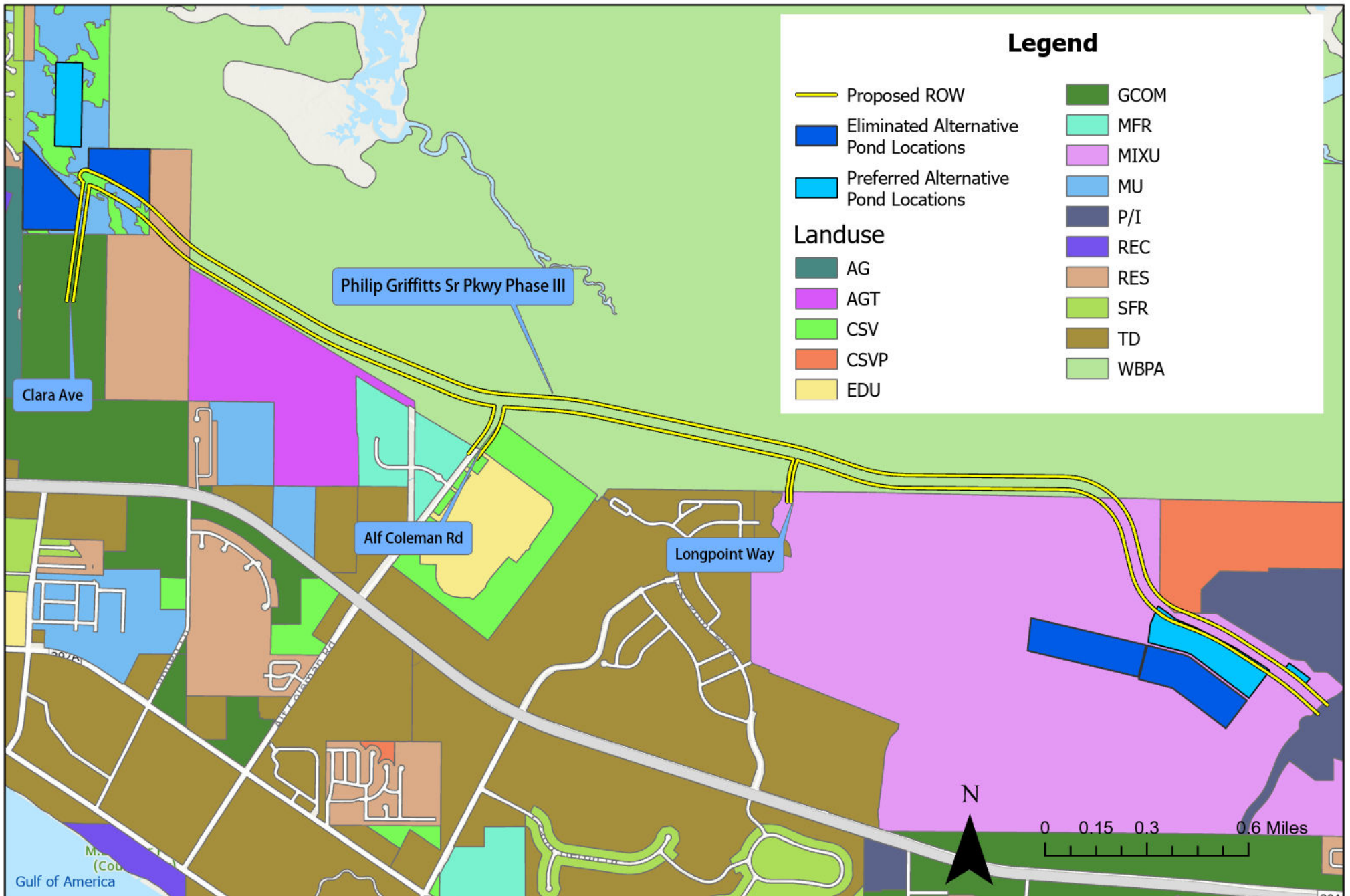

Figure 10: Land Use Map

Appendix C



Appendix D



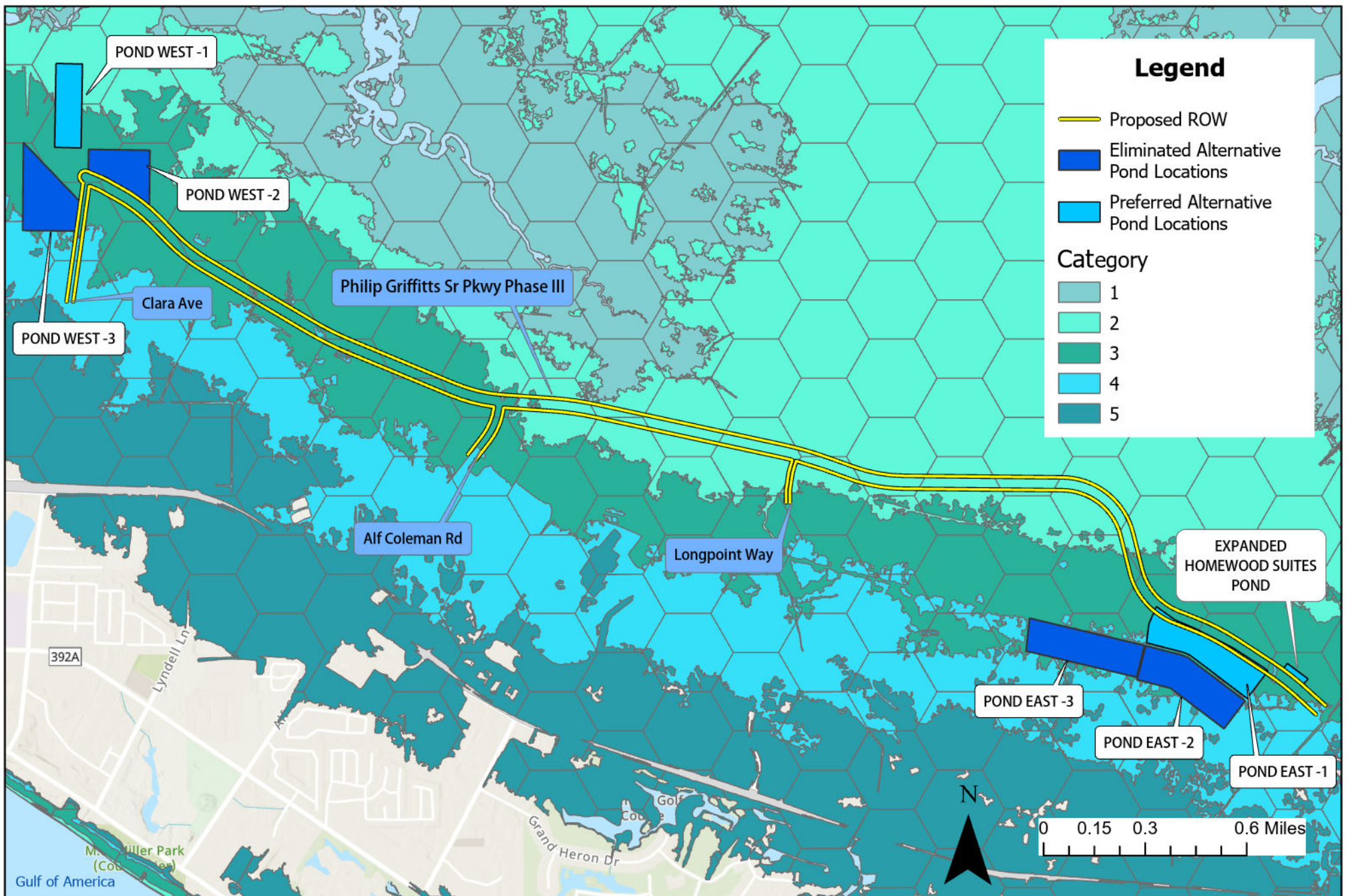

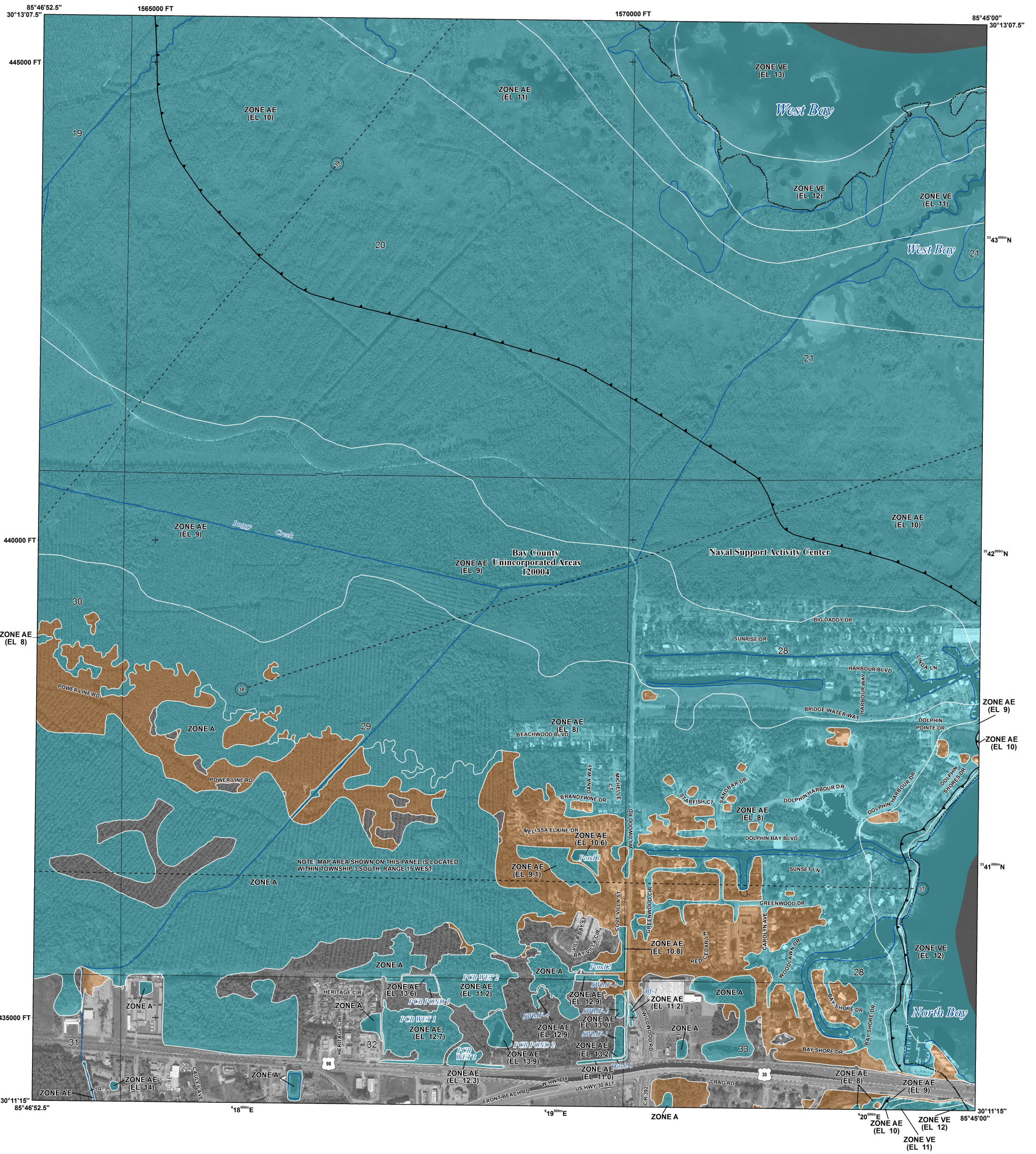

FLOOD HAZARD INFORMATION

SEE FIS REPORT FOR DETAILED LEGEND AND INDEX MAP FOR FIRM PANEL LAYOUT
THE INFORMATION DEPICTED ON THIS MAP AND SUPPORTING DOCUMENTATION ARE ALSO AVAILABLE IN DIGITAL FORMAT AT [HTTPS://MSC.FEMA.GOV](https://MSC.FEMA.GOV)

	Without Base Flood Elevation (BFE) Zone A, V, A99
	With BFE or Depth Zone AE, AO, AH, VE, AR
	Regulatory Floodway
	0.2% Annual Chance Flood Hazard, Areas of 1% annual chance flood with average depth less than one foot or with drainage areas of less than one square mile Zone X
	Future Conditions 1% Annual Chance Flood Hazard Zone X
	Area with Reduced Flood Risk due to Levee See Notes. Zone X
	Area with Flood Risk due to Levee Zone D
	Area of Minimal Flood Hazard Zone X
	Area of Undetermined Flood Hazard Zone D
	Channel, Culvert, or Storm Sewer
	Levee, Dike, or Floodwall
	Cross Sections with 1% Annual Chance Water Surface Elevation
	Coastal Transect
	Coastal Transect Baseline
	Profile Baseline
	Hydrographic Feature
	Base Flood Elevation Line (BFE)
	Limit of Study
	Jurisdiction Boundary

NOTES TO USERS

For information and questions about this Flood Insurance Rate Map (FIRM), available products associated with this FIRM, including historic versions, the current date for each FIRM panel, how to order products or the National Flood Insurance Program (NFIP) in general, please call the FEMA Mapping and Insurance eXchange at 1-877-FEMA-MAP (1-877-336-6227) or visit the FEMA Map Service Center website at <http://mfc.fema.gov>. Available products may include previously issued Letters of Map Change, a Flood Insurance Study Report, and/or digital versions of this map. Many of these products can be ordered or obtained directly from the website.

Communities annexing land on adjacent FIRM panels must obtain a current copy of the adjacent panel as well as the current FIRM Index. These may be ordered directly from the Map Service Center at the number listed above.

For community and countywide map dates refer to the Flood Insurance Study report for this jurisdiction.

To determine if flood insurance is available in this community, contact your insurance agent or call the National Flood Insurance Program at 1-800-638-6620.

Base map information shown on this FIRM was provided in digital format by the Florida Department of Transportation (FDOT). This information was derived from digital orthophotography at a 0.5-foot resolution from photography dated 2016.

LIMIT OF MODERATE WAVE ACTION: Zone AE has been divided by a Limit of Moderate Wave Action (LMWA). The LMWA represents the approximate landward limit of the 1.5-foot breaking wave. The effects of wave hazards between the Zone VE and the LMWA (or between the shoreline and the LMWA for areas where Zone VE is not identified) will be similar to, but less severe than, those in the Zone VE.

Limit of Moderate Wave Action (LMWA)

SCALE

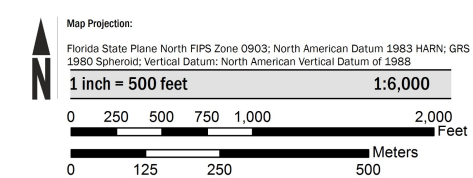

PANEL LOCATOR

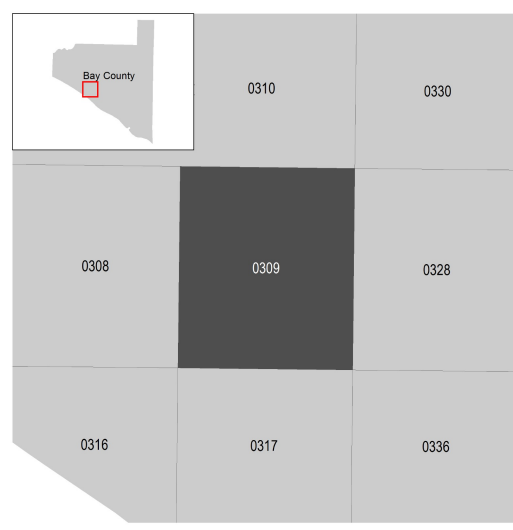

FEMA
National Flood Insurance Program

NATIONAL FLOOD INSURANCE PROGRAM
 FLOOD INSURANCE RATE MAP
BAY COUNTY, FLORIDA
 and Incorporated Areas

PANEL 309 OF 517

Panel Contains:
 COMMUNITY NUMBER PANEL SUFFIX
 BAY COUNTY 120004 0309 J

VERSION NUMBER 2.5.3.6
 MAP NUMBER 12005C0309J
 MAP REVISED OCTOBER 24, 2024

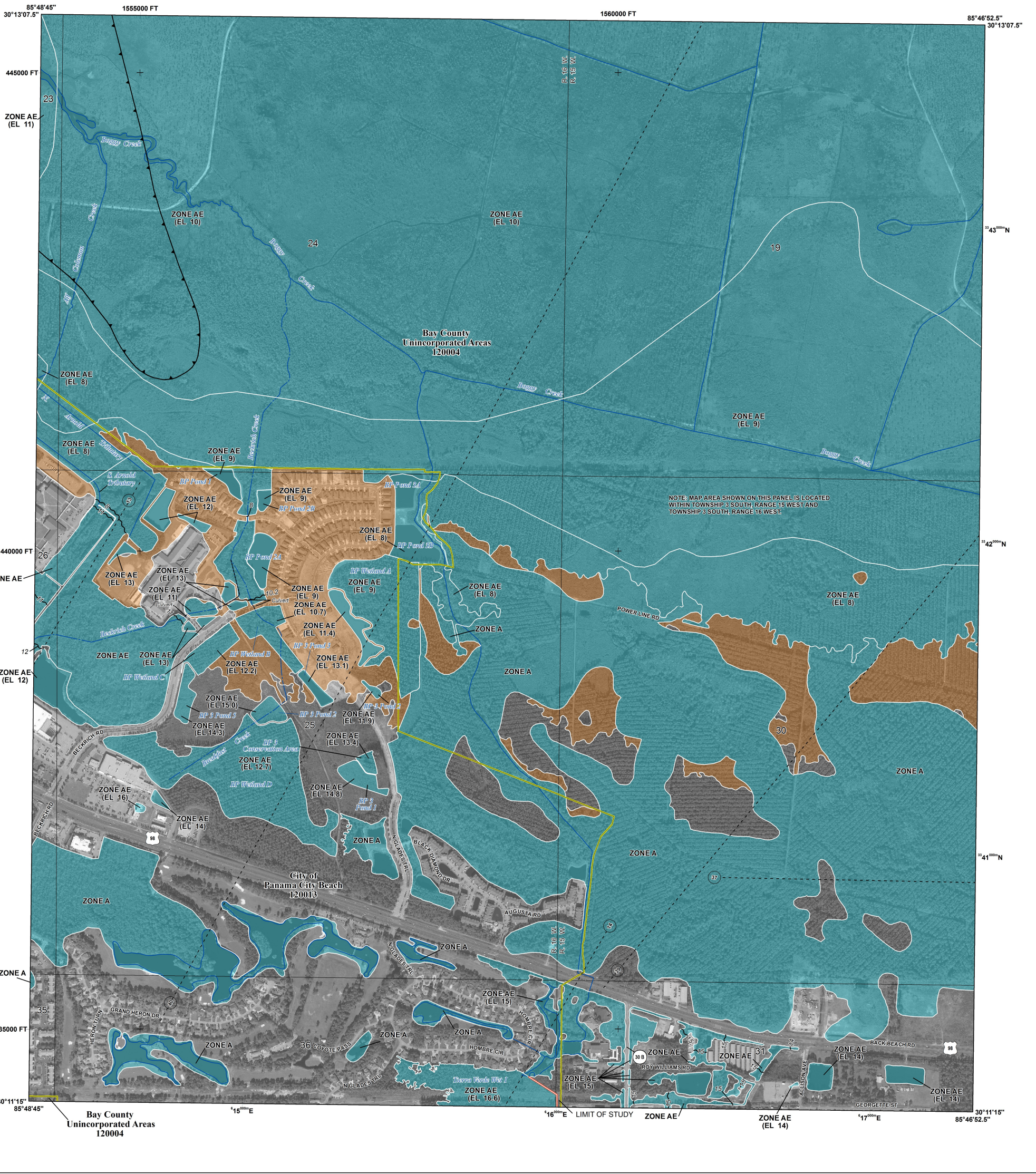

NOTE: MAP AREA SHOWN ON THIS PANEL IS LOCATED WITHIN TOWNSHIP 3 SOUTH, RANGE 16 WEST AND TOWNSHIP 3 SOUTH, RANGE 16 WEST.

FLOOD HAZARD INFORMATION

SEE FIS REPORT FOR DETAILED LEGEND AND INDEX MAP FOR FIRM PANEL LAYOUT
THE INFORMATION DEPICTED ON THIS MAP AND SUPPORTING DOCUMENTATION ARE ALSO AVAILABLE IN DIGITAL FORMAT AT [HTTPS://MSC.FEMA.GOV](https://MSC.FEMA.GOV)

	Without Base Flood Elevation (BFE) Zone A.V, A99
	With BFE or Depth Zone AE, AO, AH, VE, AR
	Regulatory Floodway
	0.2% Annual Chance Flood Hazard, Areas of 1% annual chance flood with average depth less than one foot or with drainage areas of less than one square mile
	Future Conditions 1% Annual Chance Flood Hazard Zone X
	Area with Reduced Flood Risk due to Levee See Notes. Zone X
	Area with Flood Risk due to Levee Zone D
	Area of Minimal Flood Hazard Zone X
	Area of Undetermined Flood Hazard Zone D
	Channel, Culvert, or Storm Sewer
	Levee, Dike, or Floodwall
	Cross Sections with 1% Annual Chance Water Surface Elevation
	Coastal Transect
	Profile Baseline
	Hydrographic Feature
	Base Flood Elevation Line (BFE)
	Limit of Study
	Jurisdiction Boundary

NOTES TO USERS

For information and questions about this Flood Insurance Rate Map (FIRM), available products associated with this FIRM, including historic versions, the current date for each FIRM panel, how to order products or the National Flood Insurance Program (NFIP) in general, please call the FEMA Mapping and Insurance eXchange at 1-877-FEMA-MAP (1-877-336-6227) or visit the FEMA Map Service Center website at <http://map.fema.gov>. Available products may include previously issued Letters of Map Change, a Flood Insurance Study Report, and/or digital versions of this map. Many of these products can be ordered or obtained directly from the website.

Communities annexing land on adjacent FIRM panels must obtain a current copy of the adjacent panel as well as the current FIRM Index. These may be ordered directly from the Map Service Center at the number listed above.

For community and countywide map dates refer to the Flood Insurance Study report for this jurisdiction.

To determine if flood insurance is available in this community, contact your insurance agent or call the National Flood Insurance Program at 1-800-638-6620.

Base map information shown on this FIRM was provided in digital format by the Florida Department of Transportation (FDOT). This information was derived from digital orthophotography at a 0.5-foot resolution from photography dated 2016.

LIMIT OF MODERATE WAVE ACTION: Zone AE has been divided by a Limit of Moderate Wave Action (LMWA). The LMWA represents the approximate landward limit of the 1.5-foot breaking wave. The effects of wave hazards between the Zone VE and the LMWA (or between the shoreline and the LMWA for areas where Zone VE is not identified) will be similar to, but less severe than, those in the Zone VE.



SCALE

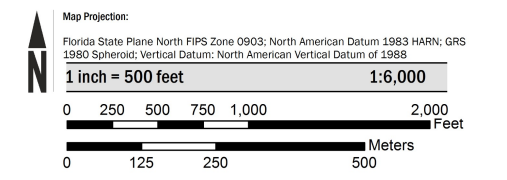

PANEL LOCATOR

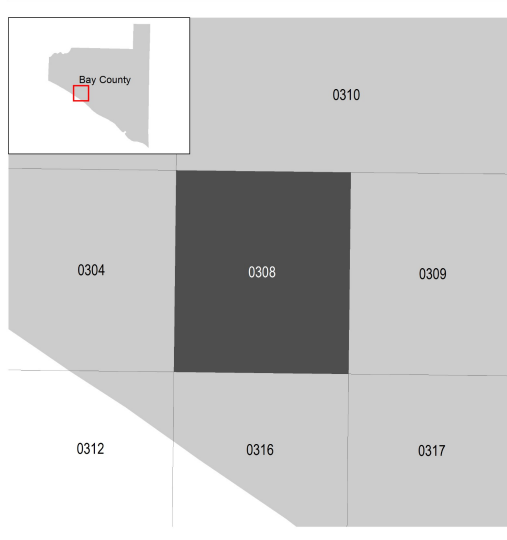

National Flood Insurance Program

NATIONAL FLOOD INSURANCE PROGRAM
 FLOOD INSURANCE RATE MAP
 BAY COUNTY, FLORIDA
 and Incorporated Areas

PANEL 308 OF 517

Panel Contains:

COMMUNITY	NUMBER	PANEL	SUFFIX
BAY COUNTY	120004	0308	J
PANAMA CITY BEACH, CITY OF	120013	0308	J

VERSION NUMBER
2.5.3.6

MAP NUMBER
12005C0308J

MAP REVISED
OCTOBER 24, 2024

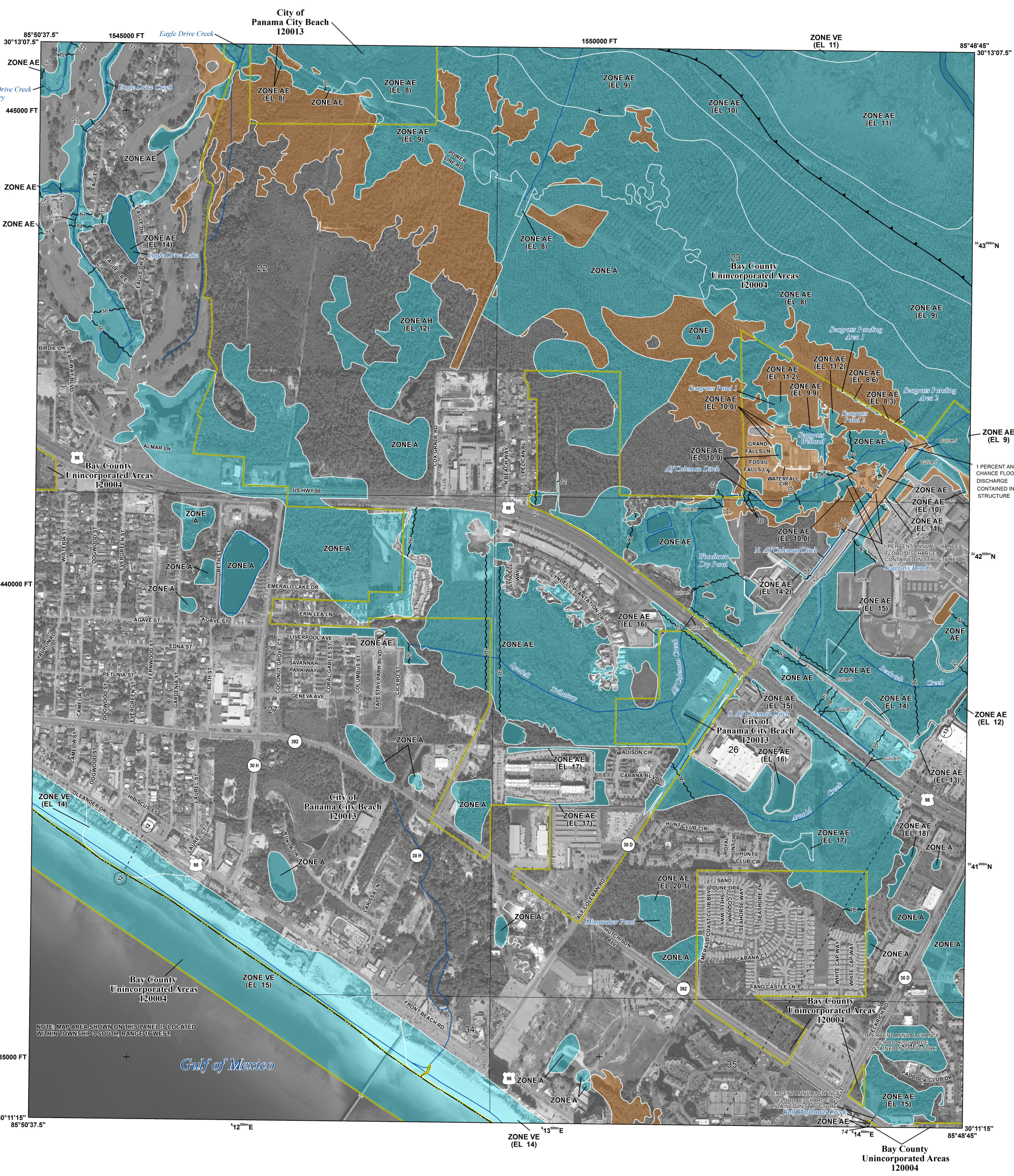

FLOOD HAZARD INFORMATION

SEE FIS REPORT FOR DETAILED LEGEND AND INDEX MAP FOR FIRM PANEL LAYOUT
THE INFORMATION DEPICTED ON THIS MAP AND SUPPORTING DOCUMENTATION ARE ALSO AVAILABLE IN DIGITAL FORMAT AT [HTTPS://MSC.FEMA.GOV](https://MSC.FEMA.GOV)

- SPECIAL FLOOD HAZARD AREAS**
 - Without Base Flood Elevation (BFE) Zone A, V, A99
 - With BFE or Depth Zone AE, AO, AH, VE, AR
 - Regulatory Floodway
- OTHER AREAS OF FLOOD HAZARD**
 - 0.2% Annual Chance Flood Hazard, Areas of 1% annual chance flood with average depths less than one foot or with drainage areas of less than one square mile Zone X
 - Future Conditions 1% Annual Chance Flood Hazard Zone X
 - Area with Reduced Flood Risk due to Levee See Notes. Zone X
 - Area with Flood Risk due to Levee Zone D
- OTHER AREAS**
 - NO SCREEN Area of Minimal Flood Hazard Zone X
 - Area of Undetermined Flood Hazard Zone D
- GENERAL STRUCTURES**
 - Channel, Culvert, or Storm Sewer
 - Levee, Dike, or Floodwall
- OTHER FEATURES**
 - Cross Sections with 1% Annual Chance Water Surface Elevation
 - Coastal Transect
 - Coastal Transect Baseline
 - Profile Baseline
 - Hydrographic Feature
 - Base Flood Elevation Line (BFE)
 - Limit of Study
 - Jurisdiction Boundary

NOTES TO USERS

For information and questions about this Flood Insurance Rate Map (FIRM), available products associated with this FIRM, including historic versions, the current date for each FIRM panel, how to order products or the National Flood Insurance Program (NFIP) in general, please call the FEMA Mapping and Insurance eXchange at 1-877-FEMA-MAP (1-877-336-6227) or visit the FEMA Map Service Center website at <http://msc.fema.gov>. Available products may include previously issued Letters of Map Change, a Flood Insurance Study Report, and/or digital versions of this map. Many of these products can be ordered or obtained directly from the website.

Communities annexing land on adjacent FIRM panels must obtain a current copy of the adjacent panel as well as the current FIRM Index. These may be ordered directly from the Map Service Center at the number listed above.

For community and countywide map dates refer to the Flood Insurance Study report for this jurisdiction.

To determine if flood insurance is available in this community, contact your insurance agent or call the National Flood Insurance Program at 1-800-638-6620.

Base map information shown on this FIRM was provided in digital format by the Florida Department of Transportation (FDOT). This information was derived from digital orthophotography at a 0.5-foot resolution from photography dated 2016.

LIMIT OF MODERATE WAVE ACTION: Zone AE has been divided by a Limit of Moderate Wave Action (LMWA). The LMWA represents the approximate landward limit of the 1.5-foot breaking wave. The effects of wave hazards between the Zone VE and the LMWA (or between the shoreline and the LMWA for areas where Zone VE is not identified) will be similar to, but less severe than, those in the Zone VE.

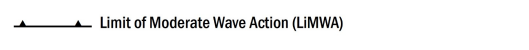

SCALE

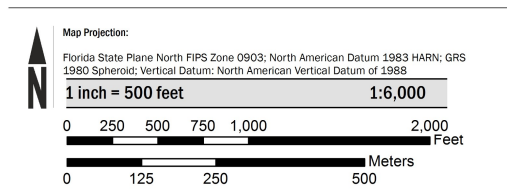

PANEL LOCATOR

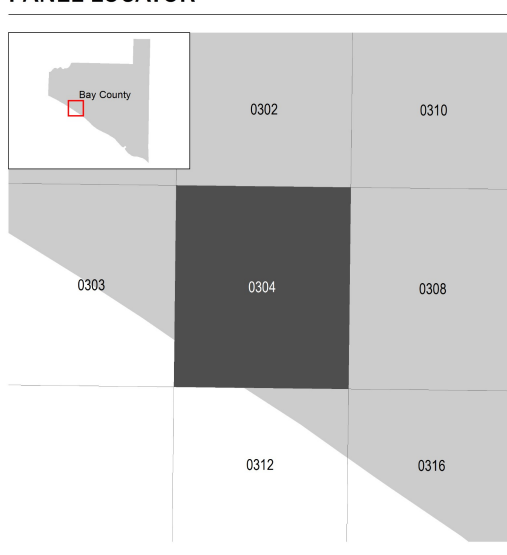

FEMA

National Flood Insurance Program

NATIONAL FLOOD INSURANCE PROGRAM

FLOOD INSURANCE RATE MAP

BAY COUNTY, FLORIDA
and Incorporated Areas

PANEL 304 OF 517

Panel Contains:

COMMUNITY	NUMBER	PANEL	SUFFIX
BAY COUNTY	120004	0304	J
PANAMA CITY BEACH, CITY OF	120013	0304	J

VERSION NUMBER
2.5.3.6

MAP NUMBER
12005C0304J

MAP REVISED
OCTOBER 24, 2024

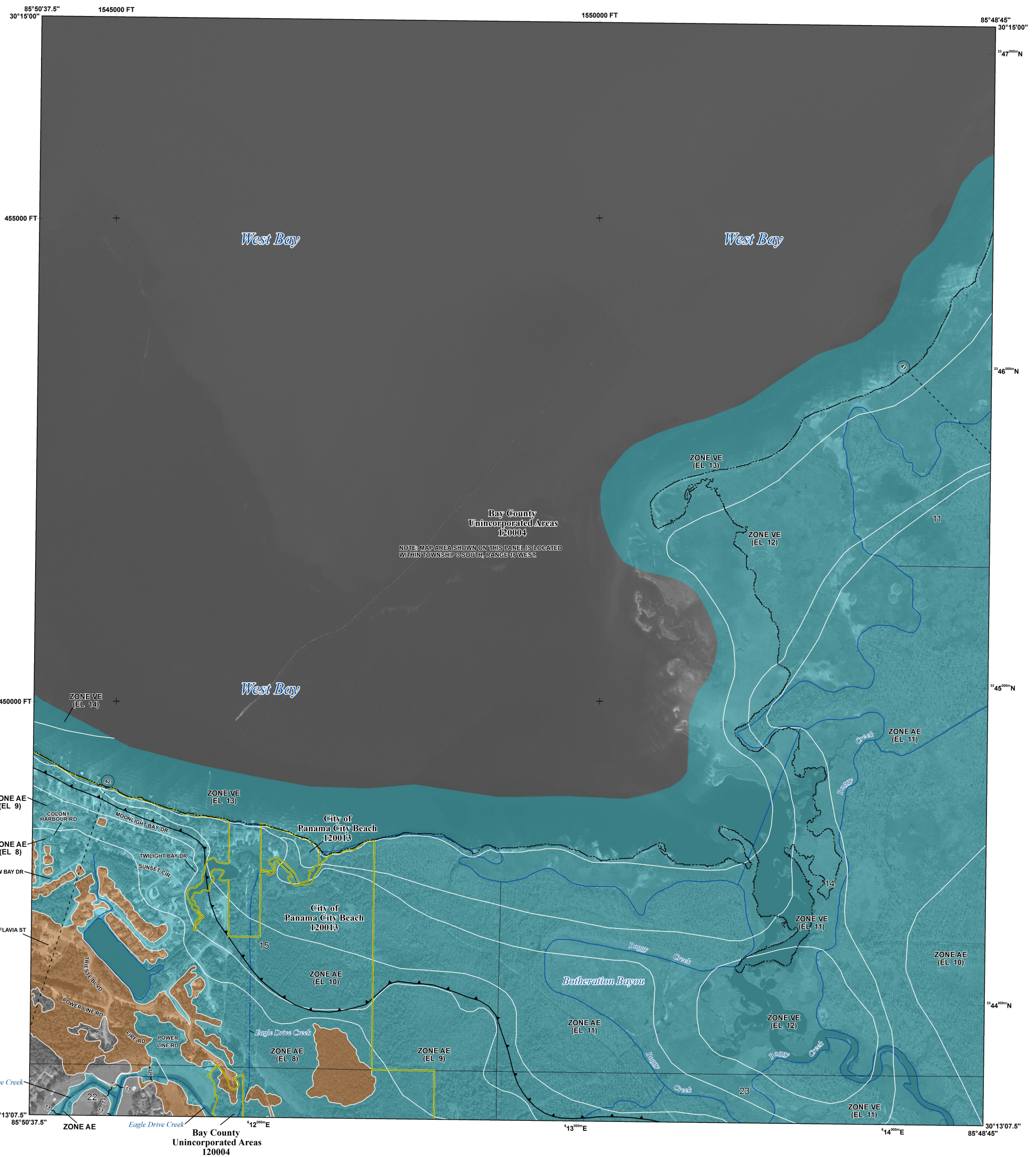

FLOOD HAZARD INFORMATION

SEE FIS REPORT FOR DETAILED LEGEND AND INDEX MAP FOR FIRM PANEL LAYOUT
THE INFORMATION DEPICTED ON THIS MAP AND SUPPORTING DOCUMENTATION ARE ALSO AVAILABLE IN DIGITAL FORMAT AT [HTTPS://MSC.FEMA.GOV](https://MSC.FEMA.GOV)

	Without Base Flood Elevation (BFE) Zone A, V, A99
	With BFE or Depth Zone AE, AO, AH, VE, AR
	Regulatory Floodway
	0.2% Annual Chance Flood Hazard, Areas of 1% annual chance flood with average depth less than one foot or with drainage areas of less than one square mile Zone X
	Future Conditions 1% Annual Chance Flood Hazard Zone X
	Area with Reduced Flood Risk due to Levee See Notes. Zone X
	Area with Flood Risk due to Levee Zone D
	Area of Minimal Flood Hazard Zone X
	Area of Undetermined Flood Hazard Zone D
	Channel, Culvert, or Storm Sewer
	Levee, Dike, or Floodwall
	Cross Sections with 1% Annual Chance Water Surface Elevation
	Coastal Transect
	Coastal Transect Baseline
	Profile Baseline
	Hydrographic Feature
	Base Flood Elevation Line (BFE)
	Limit of Study
	Jurisdiction Boundary

NOTES TO USERS

For information and questions about this Flood Insurance Rate Map (FIRM), available products associated with this FIRM, including historic versions, the current date for each FIRM panel, how to order products or the National Flood Insurance Program (NFIP) in general, please call the FEMA Mapping and Insurance eXchange at 1-877-FEMA-MAP (1-877-336-6227) or visit the FEMA Map Service Center website at <http://mac.fema.gov>. Available products may include previously issued Letters of Map Change, a Flood Insurance Study Report, and/or digital versions of this map. Many of these products can be ordered or obtained directly from the website.

Communities annexing land on adjacent FIRM panels must obtain a current copy of the adjacent panel as well as the current FIRM Index. These may be ordered directly from the Map Service Center at the number listed above.

For community and countywide map dates refer to the Flood Insurance Study report for this jurisdiction.

To determine if flood insurance is available in this community, contact your insurance agent or call the National Flood Insurance Program at 1-800-638-6620.

Base map information shown on this FIRM was provided in digital format by the Florida Department of Transportation (FDOT). This information was derived from digital orthophotography at a 0.5-foot resolution from photography dated 2016.

LIMIT OF MODERATE WAVE ACTION: Zone AE has been divided by a Limit of Moderate Wave Action (LMWA). The LMWA represents the approximate landward limit of the 1.5-foot breaking wave. The effects of wave hazards between the Zone VE and the LMWA (or between the shoreline and the LMWA for areas where Zone VE is not identified) will be similar to, but less severe than, those in the Zone VE.

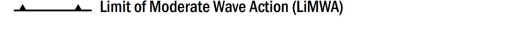

SCALE

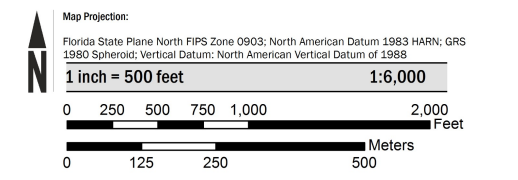

PANEL LOCATOR

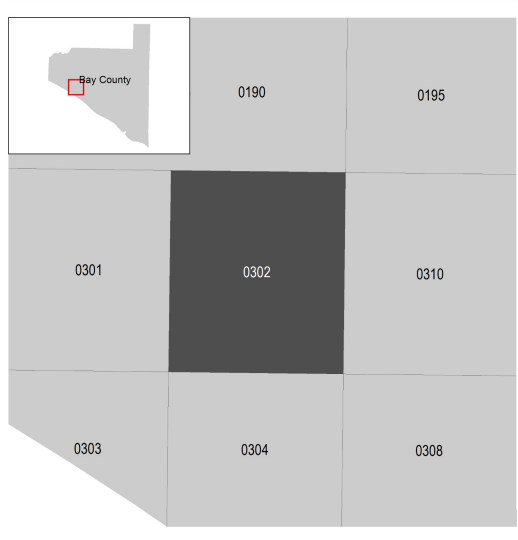

NATIONAL FLOOD INSURANCE PROGRAM
FLOOD INSURANCE RATE MAP
BAY COUNTY, FLORIDA
 and Incorporated Areas

PANEL 302 OF 517

Panel Contains:

COMMUNITY	NUMBER	PANEL	SUFFIX
BAY COUNTY	120004	0302	J
PANAMA CITY BEACH, CITY OF	120013	0302	J

VERSION NUMBER 2.5.3.6
 MAP NUMBER 12005C0302J
 MAP REVISED OCTOBER 24, 2024